

Merger m20

Flexible 2-up slit merge processing



- ✓ *Dynamic center slit justification*
- ✓ *Flexible page size formats*
- ✓ *Easy changeover from slit merge to 2-up or 3-up*
- ✓ *Pinless or pinfed paper*

Service Area

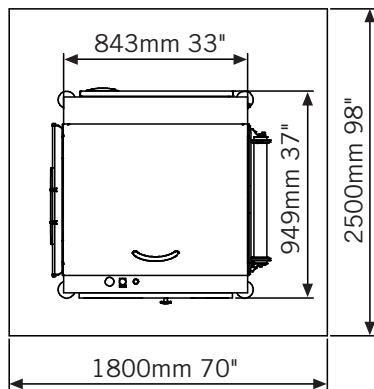

Technical Specifications

Performance / Media

Speed max.	600 ft/min	180 m/min
Feeding	Pinfed or pinless	
Paper weight	40 - 100 gsm	
Web width	5.5" - 20.5"	140 mm - 520 mm
Buffer capacity	21 ft	6.5 m

Electrical

Power	10A, 200-240 VAC, 50/60 Hz or (North America) 15A, 1 Phase, 208 V, REC=L6-15R	
Consumption	350 W (in use)	25 W (idle)
Heat output	350 W - 25 W	

Environmental

Temperature	55 - 95° F	13 - 35° C
Acoustics	70 dB(A)	
Humidity	8 - 80%	

Dimensions

Length	33"	843 mm
Width	37"	949 mm
Height	45.5"	1155 mm
Weight	573 lb	260 kg
Color	Gray	

Approvals

CE (98/37/EG), EMC Class A, LVD,
CB EN 60950, cULus 60950-1,
FCC15 Class A, VCCI

Product Specifications

